



Technology leading all-in-one brushless step motors with integrated revolutionary new control technology that prevents loss of synchronization due to transient or continued overload, extreme acceleration or deceleration, or excessive slew speed.

MDrive® AccuStep™ motion systems react quickly to large changes in loads without loss of synchronization, delivering the performance of brush, brushless and servo motors in a lower cost solution. Additional benefits include:

- No tuning;
- Higher inertia mismatch allowed;
- High starting torque;
- Smooth motion, even at extremely slow speeds.

The product's enhanced performance is accomplished using a cost effective step motor, while eliminating associated disadvantages. AccuStep control technology benefits include:

- Eliminating loss of synchronization;
- Allowing full use of motor's torque;
- Maintaining constant motor torque *with torque mode*;
- Reduced motor heating *with variable current control*;
- Minimizes impact of system resonance.

MDrive AccuStep motion systems allow a motor to handle large fluctuations in loads even at high rates of change. An available Torque Mode controls rotary and linear applications with specific torque, or force, specifications for use in applications such as web tension control, container capping, and clamping and holding.

Two MDrive AccuStep product versions are available:

**Step • Torque • Speed** – AccuStep integrated with step motor, microstepping driver and internal encoder. Step, torque and speed operating modes.

**Motion Control** – AccuStep integrated with motion controller, step motor, microstepping driver and internal encoder. Fully programmable product.

MDrive AccuStep 23 products feature a NEMA 23 1.8° brushless step motor, microstepping driver, and rugged magnetic encoder with index mark that is internal to the unit so length is not increased. Products are available in 4 rotary motor lengths. Options may include a control knob, planetary gearbox, linear actuator\* or IP65 rating\*.

Communication is over RS-422/485\*\*, with a USB to RS-422/485 Communications Converter available for ease of connecting to a user's PC. Connectivity options range from all-inclusive QuickStart Kits to individual interfacing cables and mating connector kits to build your own cables. *See pg 7.*

The MDrive AccuStep 23 accepts a broad input voltage range from +12 to +60 VDC, delivering enhanced performance and speed. The product's all-in-one design eliminates the need to run motor cabling through a machine, reducing the potential for problems due to electrical noise.

Oversized input capacitors are used to minimize power line surges, reducing problems that can occur with long runs and multiple drive systems. An extended operating range of -40° to +85°C provides long life, trouble free service in demanding environments.

With AccuStep control technology, there is now a low cost alternative where brushless technology is required. When you combine its flexible operating environment and long list of features, the integrated motor technology of MDrive AccuStep offers clear advantages in a very cost effective package for a large range of motion control applications.

\* Inquire for availability.

\*\* CANopen option for Motion Control versions.

## AccuStep™

AccuStep is a revolutionary control technology that, when applied to step motors, prevents the loss of synchronization due to transient or continued overload, extreme acceleration or deceleration, or excessive slew speed.

AccuStep control technology continually monitors the relationship between the rotor and stator at sub-microsecond intervals, and will not allow that relationship to exceed the point where synchronization is lost.

Variable current control can be enabled to allow only the required current necessary to perform the task, further enhancing performance and efficiency.

# Speed-torque performance

AccuStep revolutionary control technology allows full use of a step motor's maximum torque rating;

**eliminates derating of up to 50%**

as buffer against stalling of standard step motor systems.

Step motor max torque rating  
AccuStep control technology motor performance range with Variable Current Control

Standard step motor performance range (Design margin = 50% maximum torque as buffer against stalling)

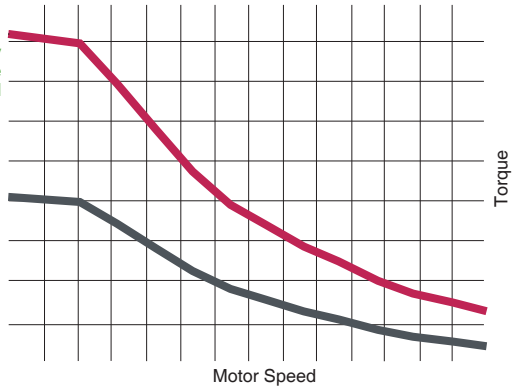

Single length motor speed-torque curves

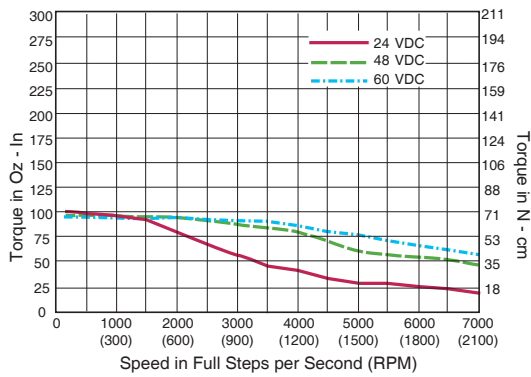

Double length motor speed-torque curves

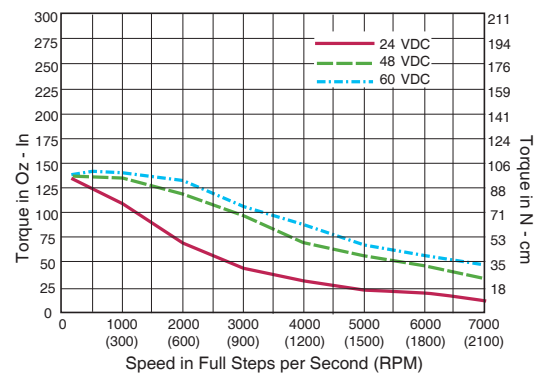

Triple length motor speed-torque curves

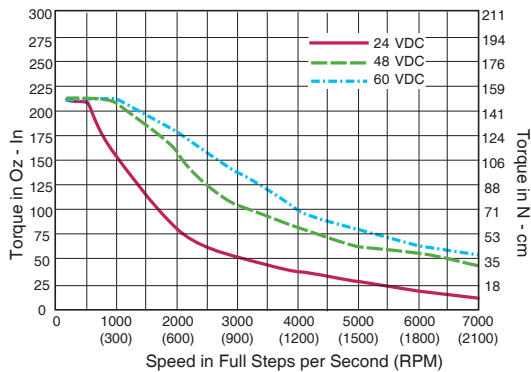

Quad length motor speed-torque curves

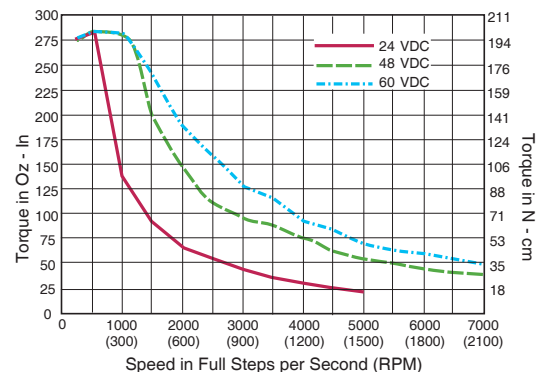

# MDrive AccuStep 23

MDrive AccuStep motion systems offer clear advantages in a very cost effective package for a wide range of motion control applications such as:

- Point-to-point positioning
  - Reduce motor frame size requirement
- Conveyor control
  - No loss of synchronization
  - Adapts to sudden load changes
- Drilling
  - Variable torque
- Web handling
  - Tension control
- Hydraulic and pneumatics replacement
  - Low cost
  - Accurate and variable positioning
- Rotary and linear positioning to torque specification
  - Container capping
  - Clamping / holding
  - Screw tightening
- On-the-fly product marking (labeling)
  - High acceleration and deceleration rates

## Motor specifications

	Holding torque	Detent torque	Rotor inertia	Weight (motor+driver)
<b>Single length</b>	90 oz-in / 64 N-cm	3.9 oz-in / 2.7 N-cm	0.0025 oz-in-sec <sup>2</sup> / 0.18 kg-cm <sup>2</sup>	21.6 oz / 612.3 g
<b>Double length</b>	144 oz-in / 102 N-cm	5.6 oz-in / 3.92 N-cm	0.0037 oz-in-sec <sup>2</sup> / 0.26 kg-cm <sup>2</sup>	26.4 oz / 748.4 g
<b>Triple length</b>	239 oz-in / 169 N-cm	9.7 oz-in / 6.86 N-cm	0.0065 oz-in-sec <sup>2</sup> / 0.46 kg-cm <sup>2</sup>	39.2 oz / 1111.3 g
<b>Quad length</b>	283 oz-in / 200 N-cm	14.2 oz-in / 10.0 N-cm	0.0108 oz-in-sec <sup>2</sup> / 0.76 kg-cm <sup>2</sup>	61.6 oz / 1746.3 g

## General specifications: all versions

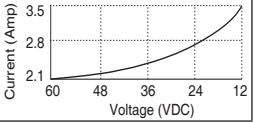
<b>Input voltage (+V)</b>	Range	+12 to +60 VDC <i>Power supply current requirements = 3.5A (maximum)</i>	
			
<b>Communication</b>	Type	RS-422/485	
	Baud rate	4.8 to 115.2kbps	
<b>Thermal</b>	Operating temperature	Heat sink	–40° to +85°C (non-condensing)
		Motor	–40° to +100°C (non-condensing)

# MDrive AccuStep 23 Step • Torque • Speed

AccuStep technology integrated with step motor, microstepping driver, velocity generator and encoder. This version operates in three different modes:

- Step Mode** operates in typical step and direction input mode for point-to-point positioning.
- Torque Mode** operates in relation to an analog input for positioning to torque setting.
- Velocity Mode** operates as an independent velocity control device, no external controller required.

## Standard specifications

<b>Isolated input</b>	Voltage range	+5 to +24 VDC sourcing or sinking		
	Digital filter range	50 nS to 12.9 μS (10 MHz to 38.8 kHz)		
<b>Motion</b>	Clock types (Step mode)	Step/Direction, Quadrature, Step Up/Step Down		
	Step frequency	5 MHz maximum 100 ns minimum pulse width		
	Closed loop configuration	Internal magnetic encoder	Resolutions 100, 200, 250, 256, 400, 500, 512, 1000	
	Microstep resolution	Number of settings	20	
		Steps per revolution	Binary	200, 400, 800, 1600, 3200, 6400, 12800, 25600, 51200, 36000 (0.01 deg/μstep), 21600 (1 arc minute/μstep), 25400 (0.001mm/μstep)
			Decimal	1000, 2000, 5000, 10000, 20000, 25000, 40000, 50000

## Setup parameters

An AccuStep configuration GUI is provided for ease of setup and configuring your device. The image (right) depicts the GUI's main screen with choice of operating mode, primary and secondary parameter settings.

Note that available settings vary with each one of the three operating modes. Shown below is an overview of all settings with general descriptions. More detailed information is covered in the product manual.

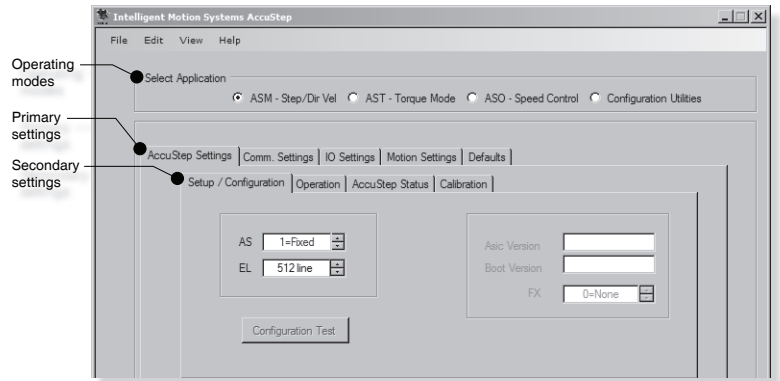

<b>Operating Mode (Select Application)</b>	Select: Step & Direction (ASM), Torque Control (AST) or Speed Control (ASO)	
<b>AccuStep Settings</b>	<b>Setup/Configuration</b>	Turn AccuStep off or on in fixed or variable mode; set and confirm encoder line count
	<b>Operation</b>	Set control bounds for motor torque and speed, lead, lag, and make-up of lost steps
	<b>AccuStep Status</b>	Display status alerts of 8 pre-programmed fields, read-only
	<b>Calibration</b>	To maintain synchronization, select options for motor's rotor-to-stator physical position
<b>Analog Settings</b>	Set analog ranges, select input mode: 0-5V, 0-10V, -10 to +10V (not applicable for Step mode)	
<b>Communication Settings</b>	Set baud rate; enable/disable parity mode and features; Check Sum integrity quality assurance	
<b>I/O Settings</b>	Clock and filter settings; Attention Output with 11 pre-programmed fields to select among	
<b>Motion Settings</b>	<b>All operating modes</b>	Set various motion settings, which vary with the operating mode selected ex. Current, MSEL
	<b>Speed control mode</b>	Additional settings: for setting acceleration, deceleration, velocity and flags
<b>Defaults</b>	Restore system defaults or previously stored settings; view current communication settings	

## Interface pin assignments

<b>P1</b> I/O and power connector	
12-pin locking wire crimp	Function
Pin 1	Power ground
Pin 2	+V (+12 to +60 VDC)
Pin 3	Optocoupler reference
Pin 4	Motion
Pin 5	Enable input
Pin 6	CW/CCW direction input
Pin 7	Aux-Power
Pin 8	Attention output emitter
Pin 9	Attention output collector
Pin 10	Analog
Pin 11	Ground
Pin 12	+5 VDC output

<b>P2</b> Communication connector	
10-pin friction lock wire crimp	Function
Pin 1	TX +
Pin 2	Communication ground
Pin 3	RX -
Pin 4	TX -
Pin 5	Communication ground
Pin 6	RX +
Pin 7	RX +
Pin 8	RX -
Pin 9	TX +
Pin 10	TX -

<b>P3</b> Internal encoder	
10-pin locking wire crimp	Function
Pin 1	Ground
Pin 2	Channel A +
Pin 3	Channel A -
Pin 4	Channel B +
Pin 5	Channel B -
Pin 6	Index +
Pin 7	Index -
Pin 8	No connect
Pin 9	No connect
Pin 10	No connect

# MDrive AccuStep 23 Motion Control

AccuStep technology integrated with step motor, microstepping driver, fully programmable motion controller and encoder. Point-to-point positioning, torque mode and velocity control are all user programmed with the feature rich MCode software and easy-to-use terminal emulator programs provided.

## Standard specifications

<b>Aux. logic input voltage</b>	Range	+12 to +24 VDC <i>Maintains power to control and feedback circuits (only) when input voltage is removed.</i>		
	<b>Analog input</b>	Resolution	10 Bit	
	Range	0 to +5 VDC, 0 to +10 VDC, 0-20 mA, 4-20 mA		
<b>General purpose I/O</b>	Number/type	8 sourcing or sinking outputs/inputs		
	Logic range	Sourcing outputs +12 to +24VDC, inputs and sinking outputs tolerant to +24VDC, inputs TTL level compatible		
	Output sink/source current	Up to 600 mA per channel		
	Protection	Over Temp, Short Circuit, Transient Over Voltage, Over Voltage, Inductive Clamp		
<b>Motion</b>	Closed loop configuration with encoder	Encoder type	Internal, magnetic	
		Steps per revolution	51200	
		Resolution	1000 lines / 4000 edges per rev	
	Counters	Type	Position, encoder	
		Resolution	32 bit	
		Edge rate (maximum)	5 MHz	
	Velocity	Range	+/- 5,000,000 steps per second	
		Resolution	0.5961 steps per second	
	Accel/Decel	Range	1.5 x 10 <sup>9</sup> steps per second <sup>2</sup>	
		Resolution	90.9 steps per second <sup>2</sup>	
High speed I/O	Position capture	Input filter range	50 nS to 12.9 μS (10 MHz to 38.8 kHz)	
		Resolution	32 bit	
	Trip output – speed / resolution / threshold	150 nS / 32 bit / TTL		
<b>Software</b>	Program storage	Type / size	Flash / 6384 bytes	
	User registers	(4) 32 bit		
	User program labels and variables	192		
	Math functions	+, -, ×, ÷, >, <, =, <=, >=, AND, OR, XOR, NOT		
	Branch functions	Branch & call		
	General purpose I/O functions	Inputs	Home, Limit Plus, Limit Minus, Go, Stop, Pause, Jog Plus, Jog Minus, General Purpose	
		Outputs	Moving, Fault, Stall, Velocity Change, General Purpose	
	Trip functions	Trip on Input, Trip on Position, Trip on Time, Trip Capture, Trip on Relative Position		
Party mode addresses	62			
Encoder functions	Stall Detection, Position Maintenance, Find Index			

## Programming

The MDrive AccuStep Motion Control version is fully programmable. Users can quickly communicate and program via a PC using IMS Terminal, an integrated ASCII terminal emulator and program editor available for download at [www.imshome.com](http://www.imshome.com).

## Interface pin assignments

P1 I/O connector	
14-pin locking wire crimp	Function
Pin 1	I/O power
Pin 2	I/O ground
Pin 3	I/O 1
Pin 4	I/O 2
Pin 5	I/O 3
Pin 6	I/O 4
Pin 7	I/O 9
Pin 8	I/O 10
Pin 9	I/O 11
Pin 10	I/O 12
Pin 11	Capture/trip I/O
Pin 12	Analog in
Pin 13	Aux power
Pin 14	Aux ground

P2 Communication connector	
10-pin friction lock wire crimp	Function
Pin 1	TX +
Pin 2	Communication ground
Pin 3	RX -
Pin 4	TX -
Pin 5	Communication ground
Pin 6	RX +
Pin 7	RX +
Pin 8	RX -
Pin 9	TX +
Pin 10	TX -

P3 Power connector	
2-pin locking wire crimp	Function
Pin 1	+V (+12 to +60 VDC)
Pin 2	Power ground

# Mechanical specifications

Dimensions in inches (mm)

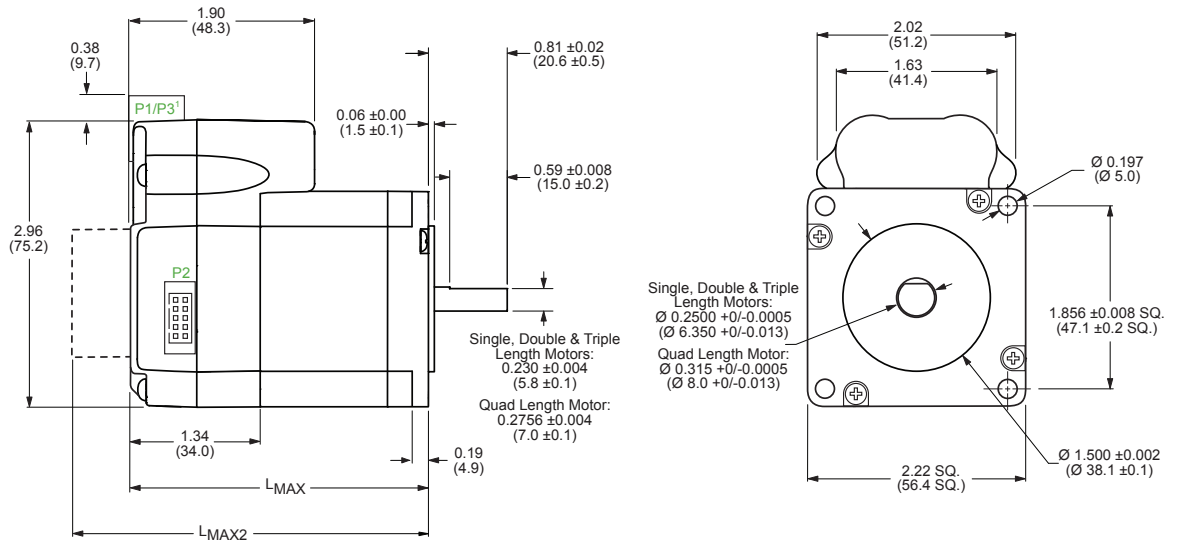

## MDrive AccuStep lengths inches (mm)

Motor length	L <sub>MAX</sub>	L <sub>MAX2</sub>
	with single shaft	with control knob
Single	2.65 (67.31)	3.36 (85.34)
Double	3.02 (76.71)	3.73 (94.74)
Triple	3.88 (98.55)	4.59 (116.59)
Quad	5.28 (134.15)	5.99 (152.19)

### L<sub>MAX2</sub> option

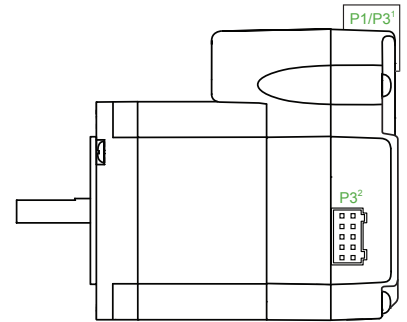
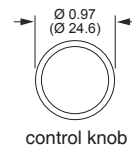

P3<sup>1</sup> Position of P3 connector on Motion Control versions.  
 P3<sup>2</sup> Position of P3 connector on Step•Torque•Speed versions.

# Order information

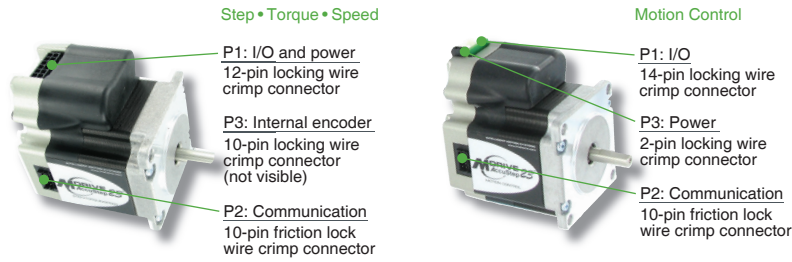

## Connectivity

### QuickStart Kit

For rapid design verification, all-inclusive QuickStart Kits have communication converter, prototype development cables, instructions and CD for MDrive AccuStep initial functional setup and system testing.

### Communication Converter

Electrically isolated, in-line converter pre-wired with mating connector to conveniently set/program parameters for a single MDrive AccuStep via a PC's USB port. Length 12.0' (3.6m).

Mates to:  
P2 connector .....MD-CC402-001

### Prototype Development Cables

Speed test/development with pre-wired mating connectors that have flying leads opposite end. Cable lengths 10.0' (3.0m), except ED-CABLE-JST10 which is 6.0' (1.8m).

Mates to:      *Step•Torque•Speed*      *Motion Control*  
P1 connector .....PD12-1434-FL3 .....PD14-2334-FL3  
P2 connector .....PD10-1434-FL3 .....PD10-1434-FL3  
P3 connector .....ED-CABLE-JST10 .....PD02-2300-FL3

### Mating Connector Kits

Use to build your own cables. Kit contains 5 mating shells with pins. Cable not supplied. Manufacturer's crimp tool recommended.

Mates to:      *Step•Torque•Speed*      *Motion Control*  
P1 connector .....CK-03 .....CK-09  
P2 connector .....CK-02 .....CK-02  
P3 connector .....CK-13 .....CK-04

## Options

### Linear Actuator

Integrated MDrive non-captive shaft and external shaft linear actuators are available with AccuStep control technology. Contact the factory for product specifications.

### Control Knob

MDrive AccuStep is available with a factory-mounted rear control knob for manual shaft positioning.

### Planetary Gearbox

Efficient, low maintenance planetary gearboxes are offered assembled with the MDrive AccuStep. Refer to details and part numbers on the back cover.

## Encoder

### Step • Torque • Speed Versions

An internal differential magnetic encoder with index mark is included with signals made available for external use. Resolutions from 100 to 1000 lines are available.

### Motion Control Versions

A 1000 line internal differential magnetic encoder with index mark is included for requisite closed loop configuration.

**NOTE: AccuStep control performance is optimized at the higher resolution selections.**

## Part numbering

### Step • Torque • Speed version

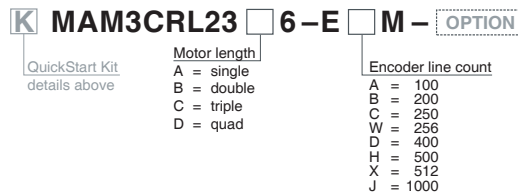

### Motion Control version

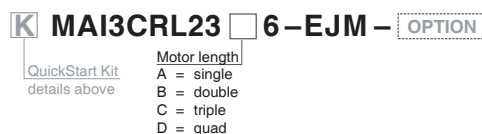

### Options

**Linear Actuator**      **-L**  
Contact factory for availability.

**Control Knob**      **-N**

Ex: **MAM3CRL23A6-EAM-N** adds a rear control knob for manual positioning to example part number.

**Planetary Gearbox**      **-G**    **-F**  
Optional NEMA Flange

Refer to gearbox page for complete table of ratios and part numbers.  
Ex: **MAM3CRL23A6-EAM-G1A2** adds 1-stage planetary gearbox with 5.18:1 ratio to example part number. Add **-F** for optional NEMA flange.

Example part number: **MAM3CRL23A6-EAM** is an MDrive AccuStep 23 Step • Torque • Speed with locking wire crimp I/O and power interface, RS-422/485 communication via a friction lock crimp connector, NEMA 23 single length motor, 100 line count internal differential magnetic encoder.

# Planetary gearbox

The MDrive AccuStep 23 is available with a Planetary Gearbox option developed to increase torque at lower speeds, enable better inertia matching and produce finer positional resolutions. These efficient, low maintenance Planetary Gearbox come fully assembled with the MDrive and are offered in a large number of reduction ratios in 1-, 2- and 3-stage configurations. An optional NEMA Output Flange allows mounting the Planetary Gearbox to the load using a standard NEMA bolt circle.

## Parameters

	Permitted output torque (oz-in/Nm)	Gearbox efficiency	Maximum backlash	Output side with ball bearing			
				Maximum load (lb-force/N)		Weight (oz/g)	
				Radial	Axial	Gearbox	with Flange
<b>1-stage</b>	566/4.0	0.80	0.70°	45/200	13/60	25.0/711	25.9/735
<b>2-stage</b>	1699/12.0	0.75	0.75°	72/320	22/100	32.2/914	33.3/945
<b>3-stage</b>	3540/25.0	0.70	0.80°	101/450	34/150	39.4/1117	40.7/1155

Dimensions in inches (mm)

\*Gearbox without Flange  
†Gearbox with Flange

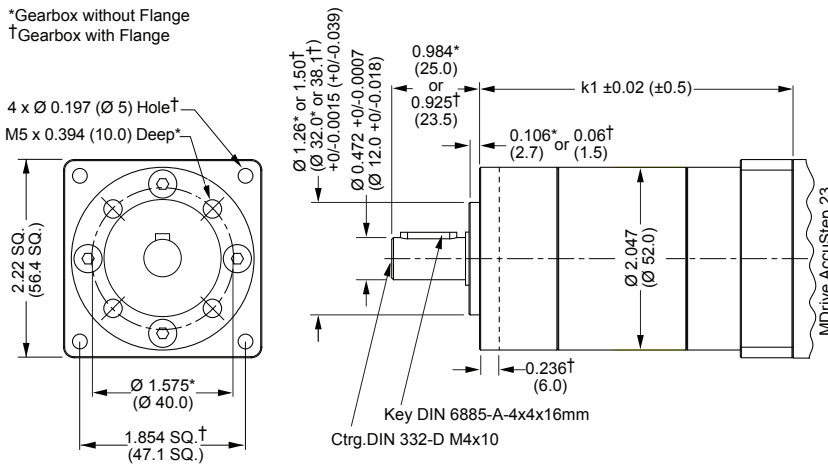

Gearbox lengths in inches (mm)

	k1	
	Gearbox*	with Flange†
1-Stage	2.976 (75.6)	3.035 (77.1)
2-Stage	3.537 (89.7)	3.59 (91.2)
3-Stage	4.087 (103.8)	4.146 (105.3)

## Ratios and part numbers

Planetary gearbox	Ratio (rounded)	Part number**
1-Stage	3.71:1	G1A1
1-Stage	5.18:1	G1A2
1-Stage	6.75:1	G1A3
2-Stage	13.73:1	G1A4
2-Stage	15.88:1	G1A5
2-Stage	18.37:1	G1A6
2-Stage	19.20:1	G1A7
2-Stage	22.21:1	G1A8
2-Stage	25.01:1	G1A9
2-Stage	26.85:1	G1B1
2-Stage	28.93:1	G1B2
2-Stage	34.98:1	G1B3
2-Stage	45.56:1	G1B4
3-Stage	50.89:1	G1B5
3-Stage	58.86:1	G1B6
3-Stage	68.07:1	G1B7
3-Stage	71.16:1	G1B8
3-Stage	78.72:1	G1B9
3-Stage	92.70:1	G1C1
3-Stage	95.18:1	G1C2
3-Stage	99.51:1	G1C3
3-Stage	107.21:1	G1C4
3-Stage	115.08:1	G1C5
3-Stage	123.98:1	G1C6
3-Stage	129.62:1	G1C7
3-Stage	139.14:1	G1C8
3-Stage	149.90:1	G1C9
3-Stage	168.85:1	G1D1
3-Stage	181.25:1	G1D2
3-Stage	195.27:1	G1D3
3-Stage	236.10:1	G1D4
3-Stage	307.55:1	G1D5

\*\*Include optional planetary gearbox by adding -G plus 3 characters to the end of an MDrive AccuStep part number.

## Schneider Electric Motion USA

370 North Main Street, P.O. Box 457  
 Marlborough, CT 06447 - U.S.A.  
 Tel. +00 (1) 860 295-6102 - Fax +00 (1) 860 295-6107  
 e-mail: info@imshome.com  
 http://www.schneider-electric-motion.us

**IMS**  
 INTELLIGENT MOTION  
 SYSTEMS, INC.

**Schneider**  
 Electric